

FRONT ELEVATION VIEW

SCALE: 1:30

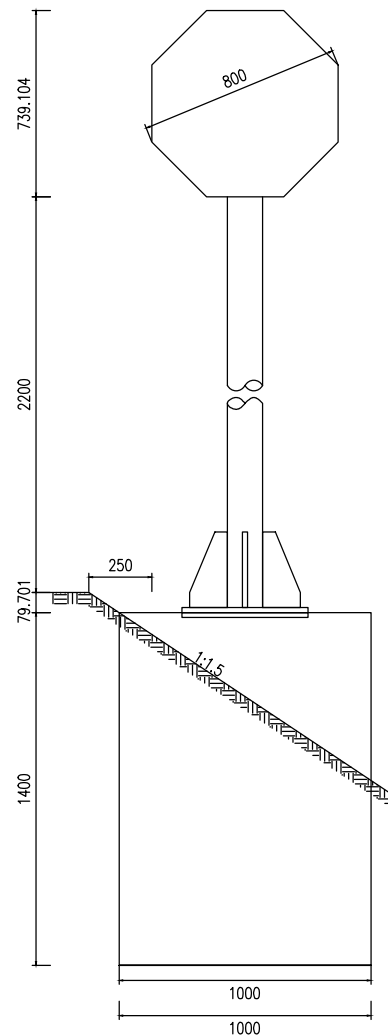

SIDE ELEVATION VIEW

SCALE: 1:30

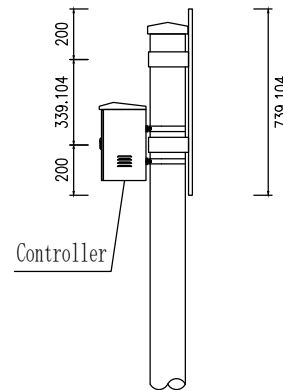
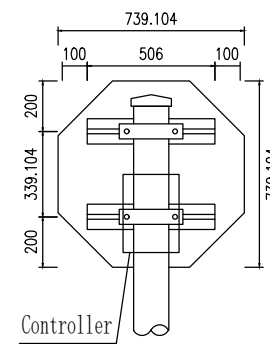

DIAGRAM OF CONNECTION BETWEEN SIGN BOARD AND COLUMN

SCALE: 1:30



PLAN VIEW OF THE BASE

SCALE: 1:30

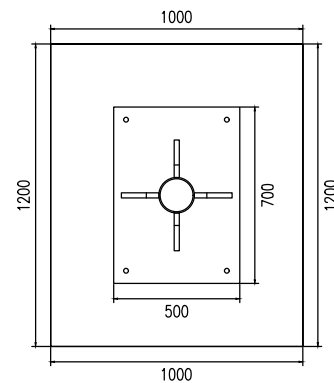

**QUANTITY TABLE OF SIGN MATERIALS
(EXCLUDING FOUNDATIONS AND SIGN BOARD)**

Material name	Specifications(mm)	Single piece weight(Kg)	Piece	Weight(Kg)	Notes
Sliding aluminum groove	100×30×4×506	1.148	2	2.295	3003
Hoop	60×6×363.411	1.027	2	2.054	
Hoop bottom lining	60×6×271.966	0.769	2	1.537	
Connecting bolts	M20×100	0.304	4	1.216	45 # steel
Nut	M20	0.062	4	0.248	45 # steel
Grommet	20	0.025	4	0.1	
Column	∅140×4.5×2920	43.917	1	43.917	
Column cap	∅140	1.397	1	1.397	
Foundation stiffening flange plate	500×700×20	54.95	1	54.95	
Basic stiffeners	300mm high	5.181	4	20.724	
Controller			1		
Active light-emitting traffic signs			1		

NOTES:

1. ALL DIMENSIONS IN THIS DRAWING ARE IN MILLIMETERS.
2. THE SLIDING ALUMINUM GROOVE IS MADE OF 3mm THICK 3003 TYPE ALUMINUM PLATE , AND ITS TENSILE STRENGTH SHOULD BE GREATER THAN 175MP_a.
3. THE SIGNBOARD IS CONNECTED TO THE SLIDING ALUMINUM GROOVE USING 3003 RIVETS, AND THE RIVETS ON THE BOARD SURFACE SHOULD BE POLISHED SMOOTH.
4. ALL STEEL COMPONENTS SHOULD BE HOT-DIP GALVANIZED, AND THE GALVANIZED AMOUNT OF FASTENERS IS 350g/m², THE GALVANIZING AMOUNT FOR OTHER STEEL COMPONENTS IS 600g/m².
5. ALL STEEL COMPONENTS ARE MADE OF Q235 STEEL, UNLESS OTHERWISE SPECIFIED.
6. TO PREVENT RAINWATER FROM SEEPING IN, A COLUMN CAP SHOULD BE ADDED TO THE TOP OF THE COLUMN.
7. THE SIGNBOARD IS CONNECTED TO THE COLUMN WITH CLAMPS.
8. WHEN THE SIGN IS LOCATED ON THE EXCAVATION SECTION, IT SHOULD BE PLACED ON THE OUTSIDE OF THE SIDE DITCH, AND THE LENGTH OF THE COLUMN CAN BE ADJUSTED ACCORDINGLY.
9. THE SIZE OF THE SIGNBOARD IN THIS PICTURE IS FOR ILLUSTRATION ONLY, AND CUSTOM SIGNBOARD SIZES ARE ACCEPTED.



STOP Signs

Active Illuminated traffic signs with panel display

Reflective sheeting: Nikkalite™ IV

Accept customizations

PAGE: 1

ELEVATION VIEW

SCALE: 1:30

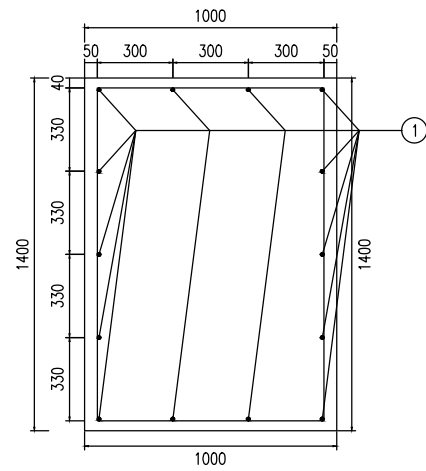

SIDE VIEW

SCALE: 1:30

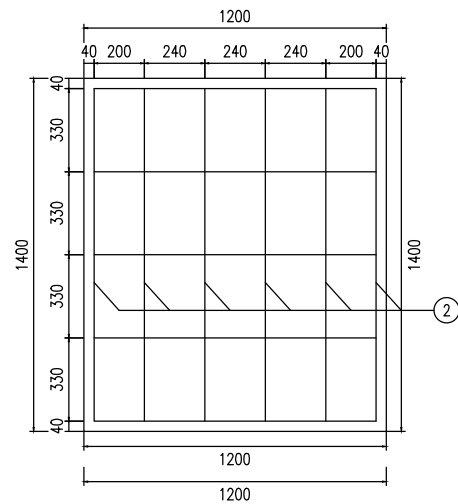

STRUCTURAL DIAGRAM OF STIFFENERS

SCALE: 1:5

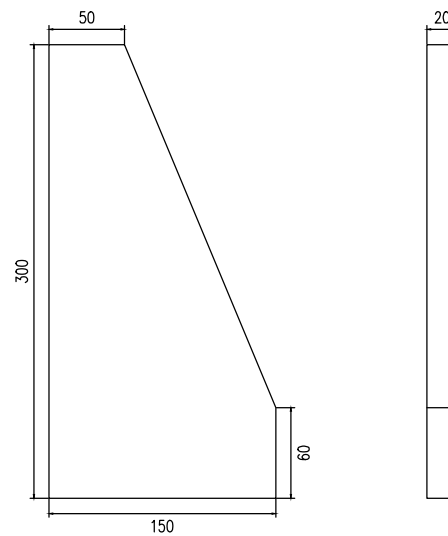

STIFFENING FLANGE PLATE

SCALE: 1:10

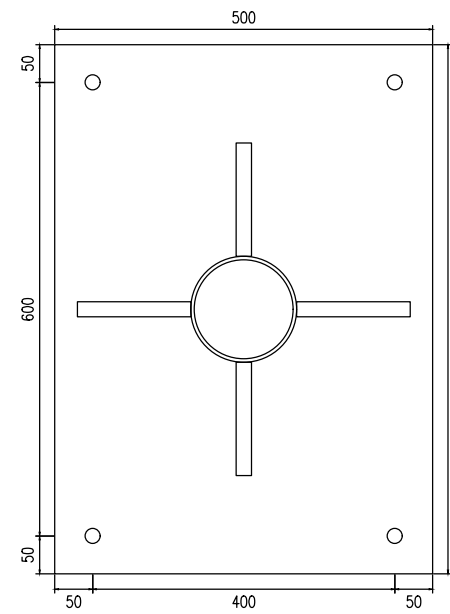

BASE FLANGE PLATE

SCALE: 1:10

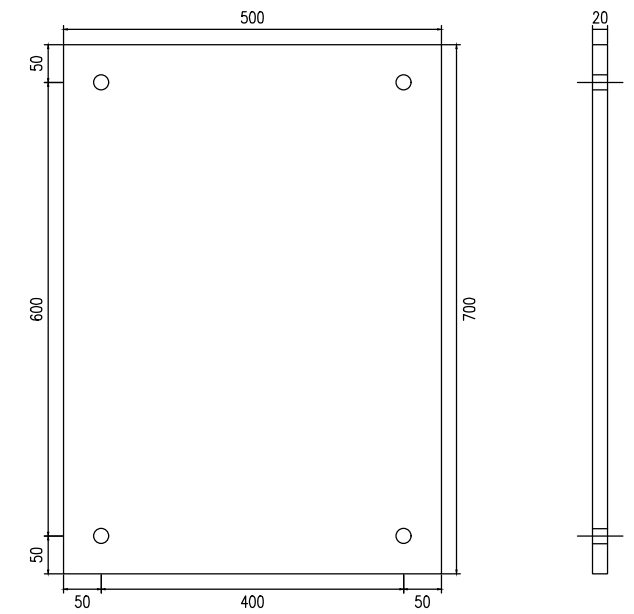

DETAILDE DRAWING OF FOUNDATION MAIN REINFORCEMENT

SCALE: 1:30

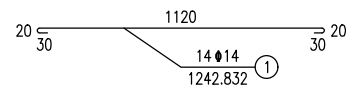

DETAILDE DRAWING OF FOUNDATION HOOP REINFORCEMENT

SCALE: 1:30

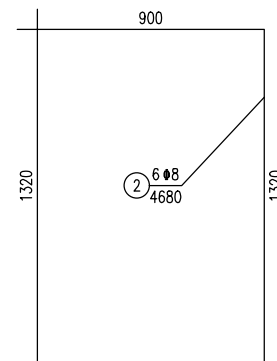

SAMPLE OF BASE CONNECTION

SCALE: 1:20

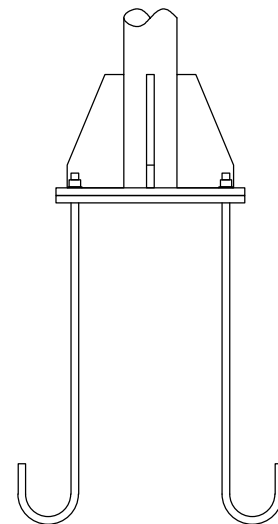

DETAILED DRAWING OF ANCHOR BOLTS

SCALE: 1:20

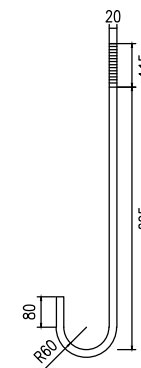

QUANTITY TABLE OF SIGN MATERIALS

Material name	Specifications(mm)	Single piece weight(Kg)	Piece	Weight(Kg)	Notes
Basic flange plate	500×700×20	54.95	1	54.95	Q235
Anchor bolt	M20×810	2.512	4	10.047	45 # steel
Nut	M20	0.062	8	0.495	45 # steel
Grommet	20	0.025	8	0.198	Q235
Rebar	∅14×1242.832	1.504	14	21.054	
Rebar	∅8×4680	1.849	6	11.092	
Foundation	1000×1200×1400			1.68 (m ³)	C25

NOTES:

1. ALL DIMENSIONS IN THIS DRAWING ARE IN MILLIMETERS.
2. THE FOUNDATION IS POURED WITH C25 CONCRETE ON SITE, AND THE CONSTRUCTION STEEL BAR ∅ 8 IS HOT-ROLLED FIRST GRADE ROUND STEEL BAR ∅ 14 IS A TWO-LAYER THREADED STEEL BAR, AND THE PROTECTION THICKNESS OF THE STEEL BAR SHOULD NOT BE LESS THAN 12mm.
3. THE TOP SURFACE OF THE FOUNDATION SHOULD BE PRE EMBEDDED WITH THE BASE FLANGE AND ANCHOR BOLTS.
THERE SHOULD BE A HOOK BELOW THE ANCHOR BOLTS TO FIX THE UPPER STRUCTURE WITH NUTS. TWO NUTS SHOULD BE ADDED TO EACH ANCHOR BOLT.
4. WHEN POURING CONCRETE, ATTENTION SHOULD BE PAID TO ALIGNING THE BASE FLANGE WITH THE FOUNDATION AND EMBEDDING IT INTO THE FOUNDATION. ITS UPPER SURFACE SHOULD BE FLUSH WITH THE TOP SURFACE OF THE FOUNDATION, WHILE ENSURING THAT ITS TOP SURFACE IS HORIZONTAL.
THE EXPOSED PART OF THE EMBEDDED ANCHOR BOLTS SHOULD BE KEPT PERPENDICULAR TO THE BASE FLANGE.
5. AFTER CONSTRUCTION IS COMPLETED, THE EXPOSED LENGTH OF THE ANCHOR BOLTS SHOULD BE CONTROLLED WITHIN 100-300mm, AND THE EXPOSED THREADED PARTS SHOULD BE PROPERLY PROTECTED.



STOP Signs

Active Illuminated traffic signs with panel display

Reflective sheeting: Nikkalite™ IV

Accept customizations

PAGE: 2

DETAILED DRAWING OF SLIDING BOLT

SCALE: 1:2

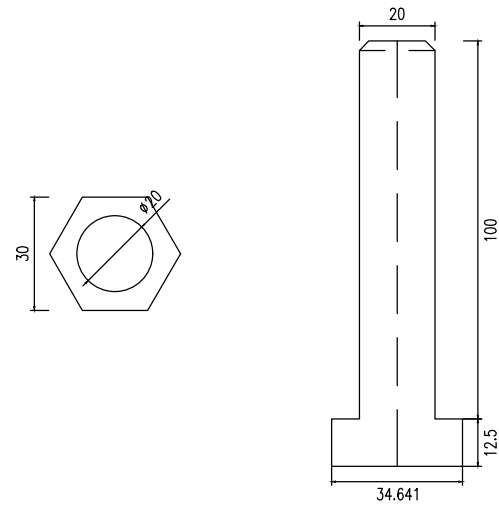

DETAILED DRAWING OF SLIDING NUT

SCALE: 1:2

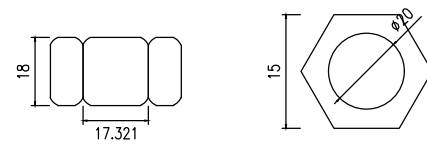

DETAILED DRAWING OF GSSKET

SCALE: 1:2

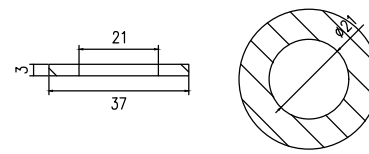

DETAILED DRAWING OF SLIDING ALUMINUM GROOVE

SCALE: 1:2

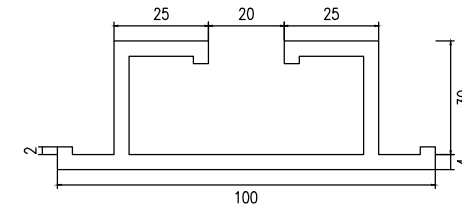

SLIDING ALUMINUM GROOVE CONNECTION DIAGRAM

SCALE: 1:2

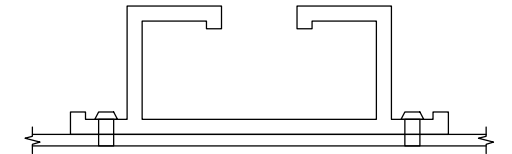

DETAILED DRAWING OF COLUMN CAP

SCALE: 1:2

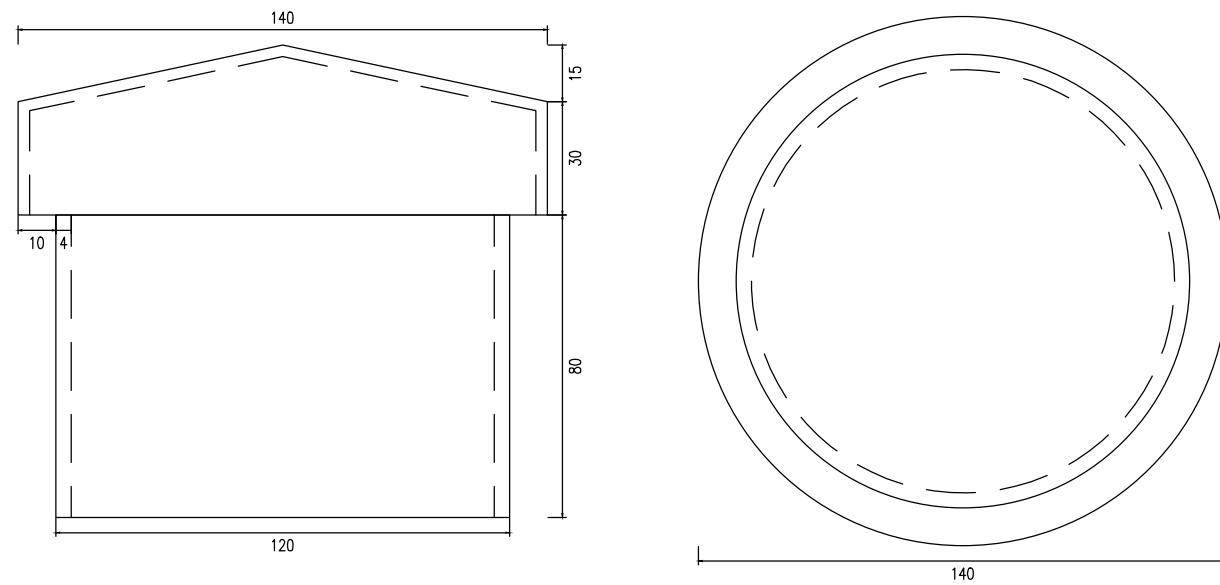

DETAILED DRAWING OF HOOP

SCALE: 1:5

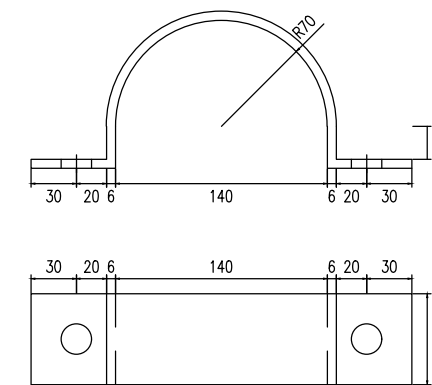

DETAILED DRAWING OF HOOP BOTTOM LINING

SCALE: 1:5

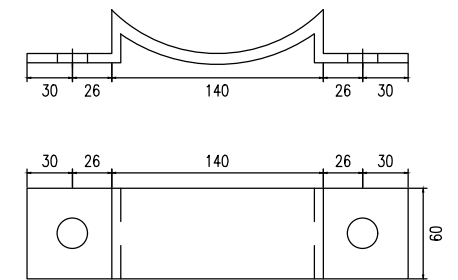

NOTES:

1. ALL DIMENSIONS IN THIS DRAWING ARE IN MILLIMETERS.



STOP Signs

Active Illuminated traffic signs with panel display

Reflective sheeting: Nikkalite™ IV

Accept customizations

PAGE: 3